

LITHIONICS BATTERY®

LITHIUM-ION IRON PHOSPHATE BATTERY SYSTEMS



12-51-2000 DC to DC BOOST CHARGER
PART NUMBER: 52-158-12-51-2000

2000 WATTS

EXTERNAL
ACCESSORIES

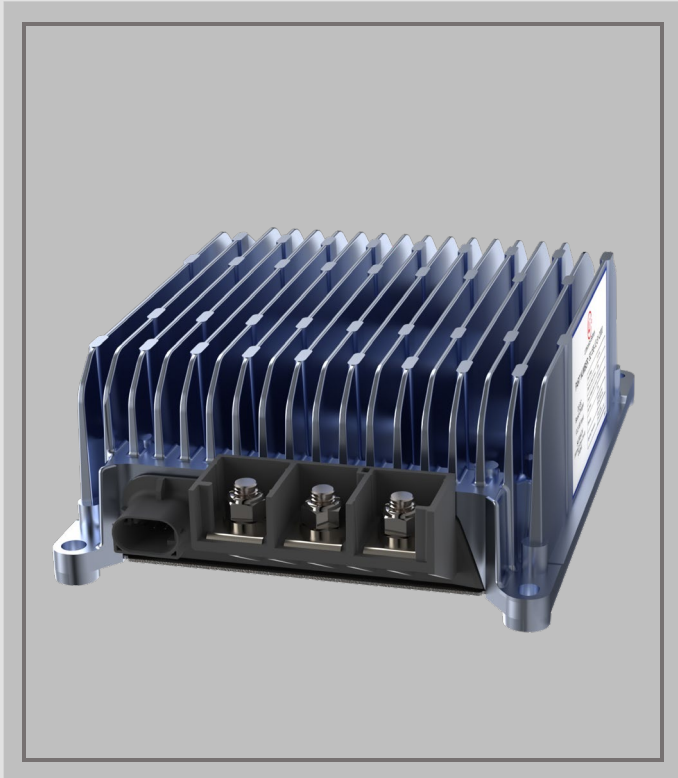

This DC-DC boost charger is engineered using advanced high-frequency power conversion technology for efficiently transferring power from a high-output 12V alternator to a 51V house battery for charging. Its features include a compact form factor, high efficiency, regulated voltage, and robust protective functions. It's an ideal solution for applications where a reliable, regulated, and efficient power transfer is critical, such as in service trucks and other specialized vehicles.

With a power rating of 2000W, this charger will draw up to 150A from the 12V alternator. To ensure proper operation, it must be used with an appropriately sized alternator and conductors which can handle such loads. For applications with smaller alternators, we recommend contacting Lithionics to inquire about custom programming for the 12V side current limit. This customization will help ensure compatibility and safe operation.

Specifications	
Input Voltage	13.2-16V
Output Voltage	54.0V±0.2V (56.0V±0.2V Open Circuit)
Max Output Current	38A
Idle Power	2W
Operating Temperature	-40 to 120C (linear derate 85C to 120C)
Efficiency	≥90% @5% load, ≥95% @100% load
Dimensions	9.4" x 6.9" x 3.0"
Weight	6.5lbs
Environmental Enclosure	IP67

Note: If the DCDC is installed in an enclosed environment, an external fan is highly recommended.

FEATURE HIGHLIGHTS

- ✓ Water & Vibration Resistant
- ✓ Low input voltage limit of 13.2V ensures the chassis battery is not depleted when engine is not running, no need for Key Switch wiring.
- ✓ Over-Temperature Protection: Automatically reduces output current if the temperature is over 85°C.
- ✓ Short Circuit Protection: Shuts down and auto-resets when short is removed.
- ✓ Under Voltage Protection: Shuts down when the voltage of the battery is too low to avoid over-discharge of the battery.

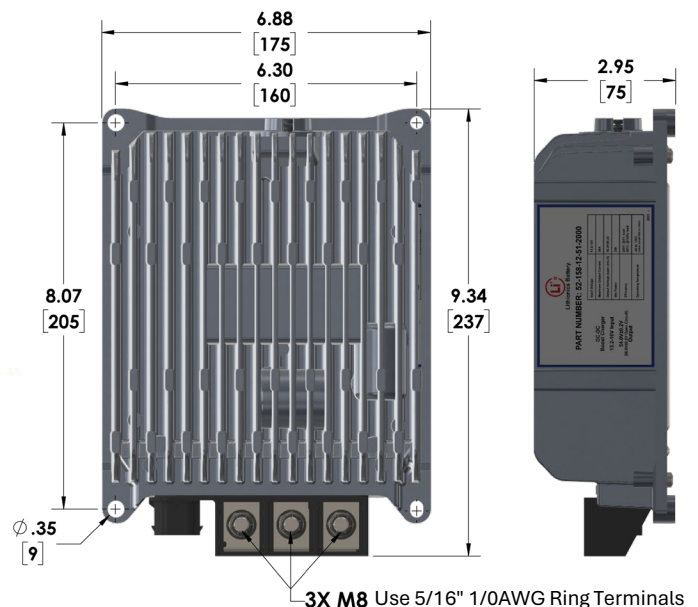

NOTE: DAMAGE TO THE DC-DC WILL OCCUR IF YOU SWAP INPUT AND OUTPUT WIRES, OR IF YOU APPLY REVERSE POLARITY TO THE CONNECTORS. DO NOT OPEN THE DC-DC CASE - THERE IS A RISK OF ELECTRIC SHOCK, AND YOUR WARRANTY MAY BE VOID. CONTACT LITHIONICS BATTERY® FOR A USER INSTALLATION GUIDE & STORAGE PROCEDURES. FOLLOW THEGUIDE TO ENSURE FITNESS OF USE & WARRANTY.

LITHIONICS BATTERY®

LITHIUM-ION IRON PHOSPHATE BATTERY SYSTEMS



12-51-2000 DC to DC BOOST CHARGER
PART NUMBER: 52-158-12-51-2000

EXTERNAL
ACCESSORIES

12V to 51V 2000W DC-DC BOOST CHARGER TYPICAL SYSTEM DESIGN

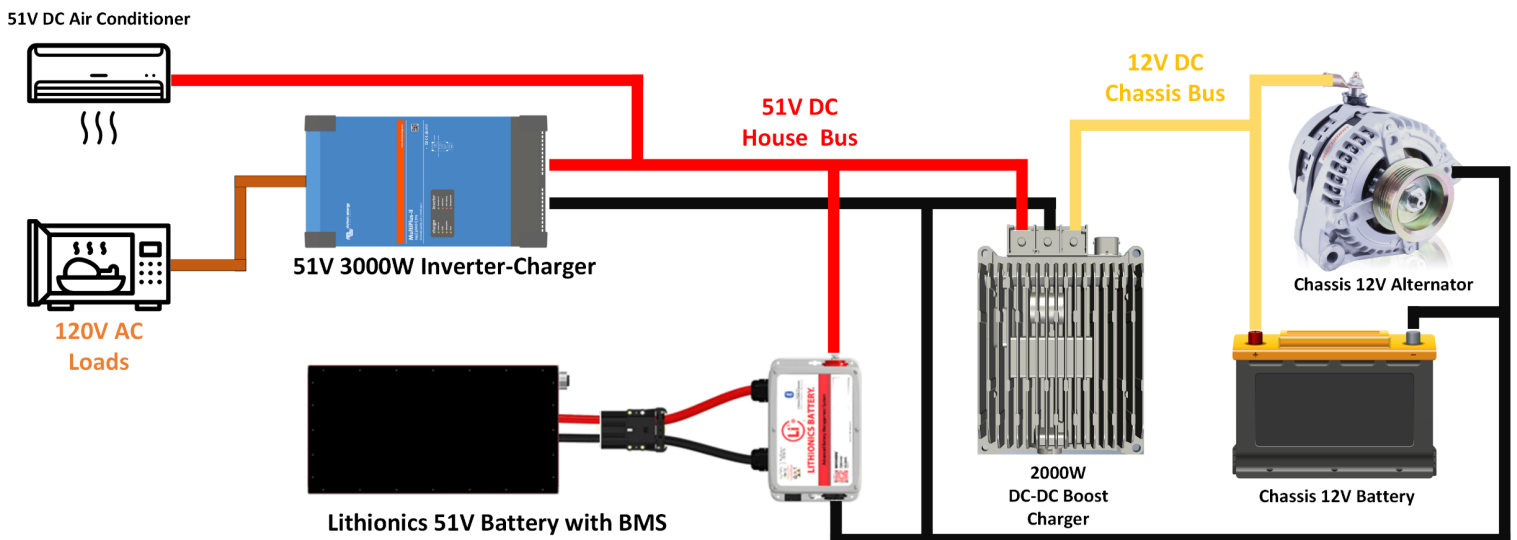

EXAMPLES OF LITHIONICS 51V DC SYSTEM ARCHITECTURE WITH BUCK OR BOOST DC CONVERTERS

Overview: Lithionics 51V Battery systems provide the most efficient way to power heavy duty consumables such as Air Conditioners, Microwave Ovens, Induction Cooktops, Refrigerators, etc. By using native 51VDC voltage we can reduce the DC current by a factor of 4x compared to legacy 12V systems, which allows for 16x reduction in I²R losses in the wires, which in turn provides longer battery runtime and less heat buildup in the electrical components. Inverter/Chargers designed for 51VDC input are readily available to power 120VAC consumables which cannot run directly on DC power.

Part Number 52-158-51-12-2500 - 51V-12V Buck DC-DC Converter: Ideally all DC consumables should run at the same 51VDC voltage as the battery, but at this time many legacy 12VDC consumables are still dominating the RV market, such as LED lights, DC Compressor fridges, slide motors, etc. A step down, a.k.a. Buck DC Converter from 51V to 12V is needed to power those consumables. Such converters must be rated for peak power required by all combined 12V loads. The Lithionics 51-12V DC-DC converter supplies up to 2500W at a high efficiency to such devices to make this possible.

Part Number 52-158-12-51-2000 - 12V-51V Boost DC-DC Charger: To charge the 51VDC battery from the vehicle engine a 2nd alternator running at 51VDC is most efficient. Lithionics Battery has developed such an alternator, called the Belted Starter Generator, or BSG. However, in some applications it might be more desirable to use an existing 12V chassis alternator, especially on larger engines with heavy duty 12V alternators capable of up to 200A or more. Lithionics can supply a 2000W Boost DC-DC Charger, which will step up charge voltage from 12V to 51V at a power rate of 2000 Watts.

System Functional Diagram: Below diagram demonstrates both the BSG and the Boost DC-DC Charger, as well as 51VDC Air Conditioner, but in each specific system design some of these components are optional, depending on specific requirements, budget, vehicle size, etc. This diagram is just an example of how different DC bus voltages are interconnected using DC-DC converters.

